



NIC Components Corp.

[www.NICcomp.com](http://www.NICcomp.com)

Technical support: [tpmq@niccomp.com](mailto:tpmq@niccomp.com)

## Double Layer Capacitors

PN: **NEX\_** series & **NED\_** series



**NEXC**  
SMT  
Reflow  
Soldering



**NEXA / NEXG**  
**NEXS / NEXT**  
Low Profile  
Radial LDD



**NEXM**  
Molded  
Radial LDD



**NEDL**  
**NEDR**  
Large Case  
Radial LDD

### Double Layer Capacitors

Also known as super capacitors, gold capacitors, ultra capacitors and farad capacitors All belong to the family of electro-chemical double layer capacitors abbreviated **EDLCs**

Feature high capacitance value (Farad) for energy storage, voltage hold-up and battery back-up applications. Double layer capacitors bridge the gap (see graph below) between conventional batteries and conventional capacitors. EDLCs store and deliver temporary (or momentary) energy to electronic circuits in wide range of low voltage (2 ~ 12VDC) circuit applications.

**Wh** = watt-hour  
is unit of energy  
equivalent to one  
watt (1 W) of  
power expended  
for one hour

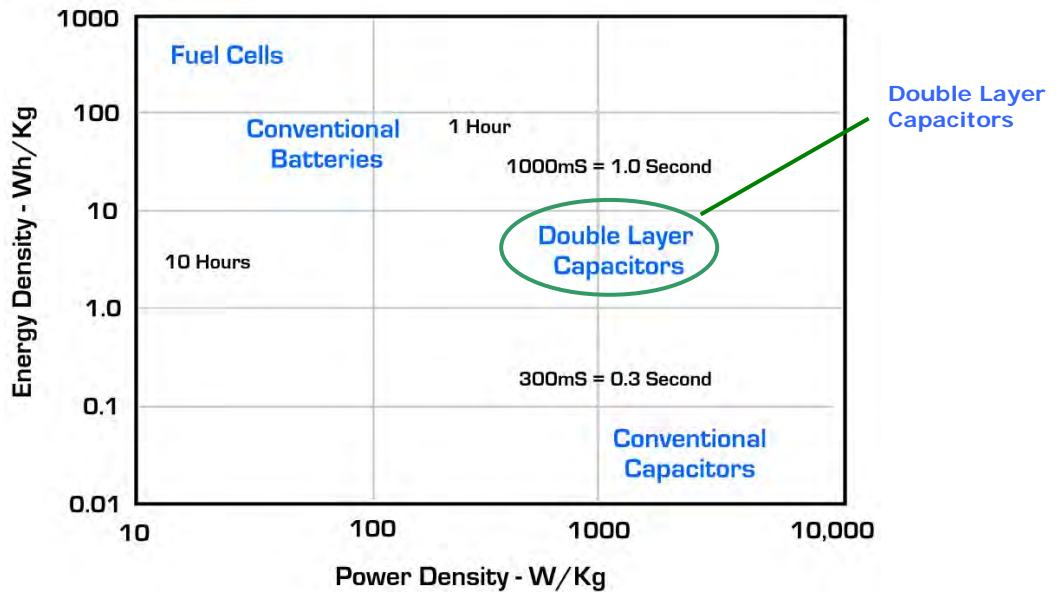

RE: **Double Layer Capacitors**

PN: **NEX\_** series & **NED\_** series

**Selection Guide: Series – Type**

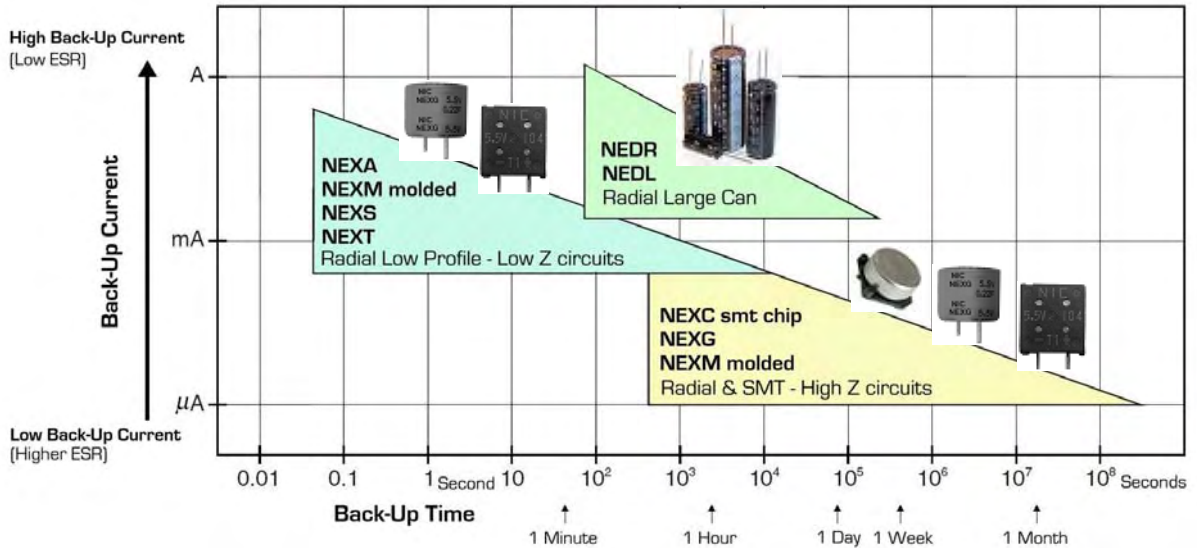

NIC Series	Type	Size (mm)	Capacitance	Voltage
<b>NEXC</b> -25°C ~ +70°C	<b>SMT Chip</b>	10.5 $\varnothing$ x 5.5 height 10.5 $\varnothing$ x 8.5 height 10.7 $\varnothing$ x 5.5 height 16 $\varnothing$ x 9.5 height 21 $\varnothing$ x 10.5 height	<b>0.047F ~ 1.0F</b> (47,000 $\mu\text{F}$ ~ 1,000,000 $\mu\text{F}$ )	<b>3.5VDC</b> <b>5.5VDC</b>
<b>NEXM</b> -25°C ~ +70°C	<b>Radial LDD Molded Case</b>	5mm LS 10.5 x 11.5 x 5.0 10.5 x 11.5 x 6.5	<b>0.01F ~ 0.22F</b> (10,000 $\mu\text{F}$ ~ 220,000 $\mu\text{F}$ )	<b>3.5VDC</b> <b>6.5VDC</b>
<b>NEDL</b> -25°C ~ +70°C <b>NEDR</b> -25°C ~ +60°C -25°C ~ +70°C	<b>Radial LDD Large Can</b>	10 $\varnothing$ x 35 height 12.5 $\varnothing$ x 25 height 12.5 $\varnothing$ x 35 height 16 $\varnothing$ x 35.5 height 18 $\varnothing$ x 40 height 18 $\varnothing$ x 50 height 22 $\varnothing$ x 50 height 22 $\varnothing$ x 65 height	<b>10F ~ 100F</b>	<b>2.5VDC</b> <b>2.7VDC</b>
<b>NEXA</b> <b>NEXG</b> <b>NEXS</b> -25°C ~ +70°C <b>NEXT</b> -40°C ~ +85°C	<b>Radial LDD Low Profile</b>	11 $\varnothing$ x 5.5 / 6.5 / 8.5 13 $\varnothing$ x 8.5 / 9 14.5 $\varnothing$ x 12 / 18 16 $\varnothing$ x 15.5 / 25 16.5 $\varnothing$ x 8.5 / 13 / 19 21.5 $\varnothing$ x 13 / 15.5 / 19 28.5 $\varnothing$ x 16.5 / 14 / 19 / 22 / 25.5 / 31.5 / 38 36.5 $\varnothing$ x 15 / 16.5 / 27.5 44.5 $\varnothing$ x 17 / 18.5 / 28.5 / 60	<b>0.01F ~ 5.6F</b> (10,000 $\mu\text{F}$ ~ 5,600,000 $\mu\text{F}$ )	<b>5.5VDC</b> <b>11VDC</b> <b>12VDC</b>

RE: Double Layer Capacitors

**NEX\_ Series Construction:**

**Double Layer Cell (~ 1.2VDC breakdown)**

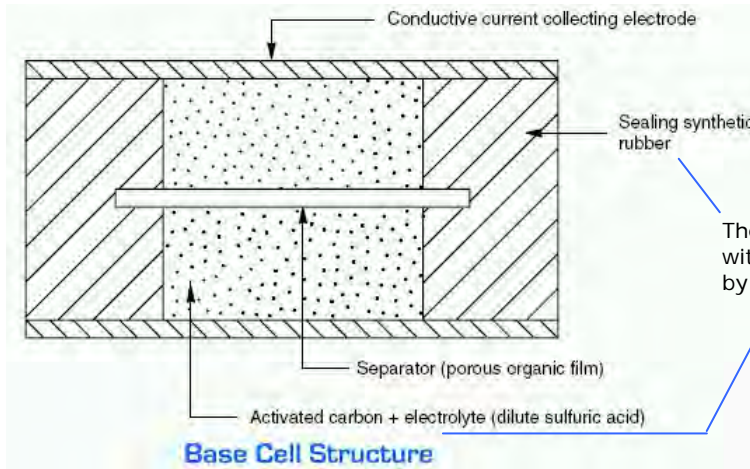

The liquid electrolyte is sealed within the capacitor element by rubber sealing material

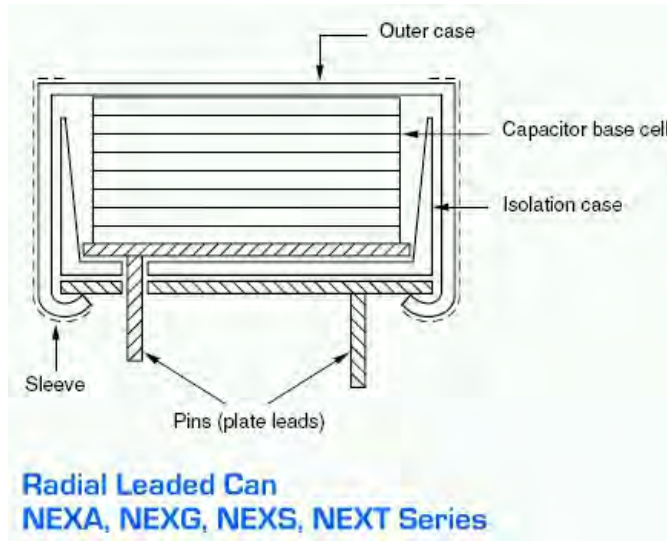

Multiple cells are connected in series, to increase the voltage rating of the capacitor



**NEXT**



**NEXM**

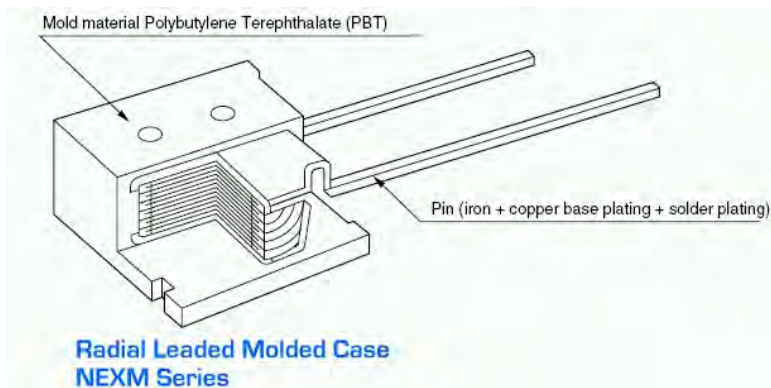

**NEXC**

## RE: Double Layer Capacitors

PN: NEX\_ series & NED\_ series



### Precautions for Use:

#### Circuit Design

##### Voltage:

- Only direct current (VDC) should be applied to double layer capacitors
- Ensure that the maximum operating voltage **does not exceed the rated voltage (VDC)**
- Application of a voltage exceeding the maximum operating voltage may deteriorate performance and damage the component.

##### Polarity:

Double layer capacitors are polarized (anode + terminal and cathode – terminal).

Please assure correct polarity when installing (or placing) component during PCB assembly.

Components have polarity indicators as follows:

- NEXC – SMT; Anode (+) notch in base-plate and top of can Cathode (-) indicator (See Image)
- NEXM – Molded case radial leaded; Polarity (+ & -) indicators on case (See Image)
- NEXA, NEXG, NEXS, NEXT – Radial leaded; Cathode (-) indicators on sleeve and case (See Image)



##### Equivalent Series Resistance (ESR):

ESR of double layer capacitors is relatively high. Do not use double layer capacitors in supply voltage smoothing circuits, such as output filter of power supply circuits

**Parallel connection** of multiple double layer capacitors is possible; please assure the voltage applied to each capacitor does not exceed the maximum operating voltage (VDC).

**For series connection** of multiple double layer capacitors, please take measures to ensure voltage is evenly distributed to all capacitors and the voltage applied to each capacitor does not exceed the maximum operating voltage (VDC).

#### Mounting - Soldering

- All radial leaded versions** of double layer capacitors **cannot withstand exposure** to reflow soldering heat. Only NEXC series can be used in reflow soldering process.
- When using flow – wave soldering process, ensure that the soldering temperature is  $\leq 260$  °C and soldering duration does not exceed 10 seconds
- For soldering with a soldering rod, select a soldering rod with a capacity of ~30W and ensure that the tip temperature  $< 400$  °C and soldering duration is less than 3 seconds
- Excessive soldering heat may increase the equivalent series resistance (ESR) of the capacitor
- Do not bend, deform or file capacitor terminals and take measures to prevent mechanical impact damage to terminals. Impact to terminals may cause damage to plating and result in poor soldering.
- All capacitors, including those with insulation sleeving should not contact adjacent components nor contact assembly case
- Use in the vicinity of a heating element (coil, power transistor, resistor, etc.) may heat the capacitor itself and considerably shorten its service life

RE: **Double Layer Capacitors**

PN: **NEX\_** series & **NED\_** series



**Precautions for Use:**

**Residual Charge**

Take precautions, as some residual potential (applied during manufacturing test) may be present on double layer capacitors as received. Voltage recovery over time may result in residual charge on component after time in transit and on shelf. Please take measures to avoid damage to other components (i.e. semiconductors) during PC assembly.

**Environment**

Double layer capacitors cannot be used in an acidic or alkaline atmospheres or liquids

**Washing**

- Do not wash double layer capacitors, except NEXM series, without reviewing washing conditions with NIC technical support [ [tpmg@niccomp.com](mailto:tpmg@niccomp.com) ]. Special washing-resistant versions may be available.
- Drying after washing of NEXM series, should be performed within the maximum operating temperature range [ $< +70^{\circ}\text{C}$ ].

**Storage**

- a. Storage Conditions:
  - Indoors
  - Temperature:  $+5^{\circ}\text{C} \sim +35^{\circ}\text{C}$  ( $41^{\circ}\text{F} \sim 95^{\circ}\text{F}$ )
  - Relative humidity: 40 to 75%
- b. Avoid exposing the components to direct sunlight for extended periods. Doing so may cause deterioration or discoloration of the insulation sleeving
- c. Do not store in an alkaline or acidic atmosphere.

**Disassembly & Disposal**

- Do not disassemble capacitor
- The capacitor electrolyte contains a trace amount of dilute sulfuric acid.
- Avoid contact as may have a harmful effect
- Do not use incineration for disposal. Instead, dispose of capacitor as industrial waste

RE: **Double Layer Capacitors**

PN: **NEX\_** series & **NED\_** series

### Component Selection Guide

If backup current requirement is **1 mA or greater**

**NEXA, NEXM, NEXS, NEXT, NEDL and NEDR** series are suggested

See discharge characteristics in **Appendix "A"**

An approximate backup time can be calculated from the following expression:

$$T \text{ (seconds)} = \frac{[ C \times (V_0 - V_1 - V_{\text{drop}}) ]}{I}$$

**C** : Double layer capacitor capacitance (Farad)

**V<sub>0</sub>** : Voltage charged in double layer capacitor (VDC)

**V<sub>drop</sub>** : Voltage drop by DC resistance with double layer capacitor (VDC)

**V<sub>1</sub>** : Minimum required voltage for backup circuit (VDC)

**I** : Backup current (Amp)

The voltage drop is determined by the DC resistance of the capacitor and backup current

**V<sub>drop</sub>** (VDC) = **DCR \* I** ... DCR = Ω & I = A (**See appendix B for DCR values**)

Example #1:

1.0F 5.5VDC, DCR = 1.1Ω, NIC PN: NEXA105Z5.5V44.5FX18.5F

- o Circuit Back-up Current; **I = 1000uA (1mA)**
- o V<sub>drop</sub> = 0.0011
- o V<sub>0</sub> = 5.0VDC
- o V<sub>1</sub> = 3.3VDC

**Back-up Time (T) = 1699 seconds (28 minutes)**

Example #2:

1.0F 5.5VDC, DCR = 1.1Ω, NIC PN: NEXA105Z5.5V44.5FX18.5F

- o Circuit Back-up Current; **I = 5000uA (5mA)**
- o V<sub>drop</sub> = 0.00011
- o V<sub>0</sub> = 5.0VDC
- o V<sub>1</sub> = 3.3VDC

**Back-up Time (T) = 339 seconds (5.65 minutes)**

If backup current requirement is **less than 1 mA** ; **NEXC, NEXG, NEXM** series are suggested

An approximate backup time can be calculated from constant resistance discharge characteristics obtained by converting the back-up current requirement to a constant resistance load

See discharge characteristics in **Appendix "A"**

RE: Double Layer Capacitors

PN: NEX\_ series & NED\_ series

## Explanation of Characteristics Terms

### 1.0 Charging Time & Current

Double layer capacitors require **much longer time to charge** than conventional capacitors.

For example; conventional aluminum or tantalum electrolytic capacitors charge, to the applied voltage (VDC), within a relatively short period of time (typically within seconds or minutes, depending upon Capacitance-Voltage). Leakage current characteristics for aluminum or tantalum electrolytic capacitors is usually specified in micro-Amperes ( $\mu\text{A}$ ) after one or two minutes of charging ( $\text{LC} = 0.01\text{CV}$  after 2 minutes).

Double layer capacitors require **many hours to fully charge (100+ Hours)**, so the typical method of measure leakage current is not applicable with respect to double layer capacitors. Most of the current flowing into a double layer capacitor after 30 minutes is charging current rather than leakage current. Typical charging currents after 1 hour of charge, can be between  $100\mu\text{A} \sim 3\text{mA}$  (GRAPH 1)

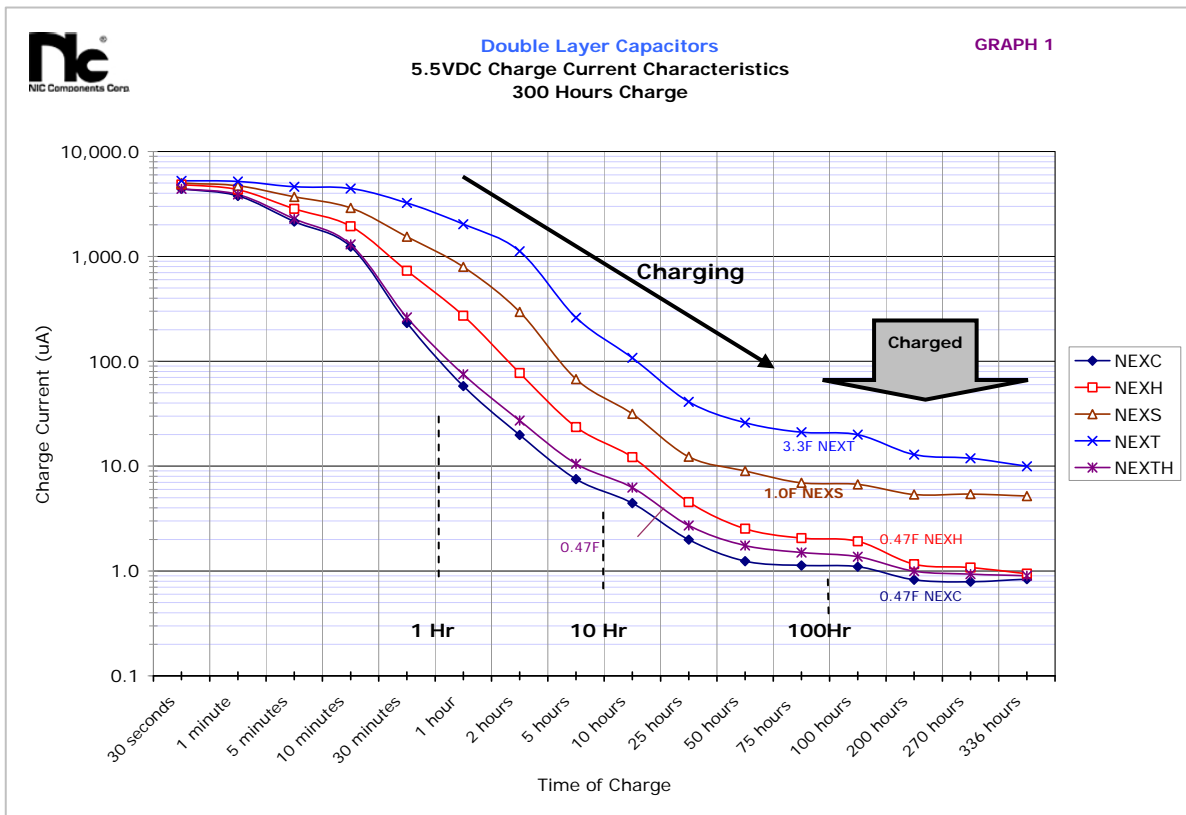

RE: Double Layer Capacitors

PN: NEX\_ series & NED\_ series

Charge Current over Time

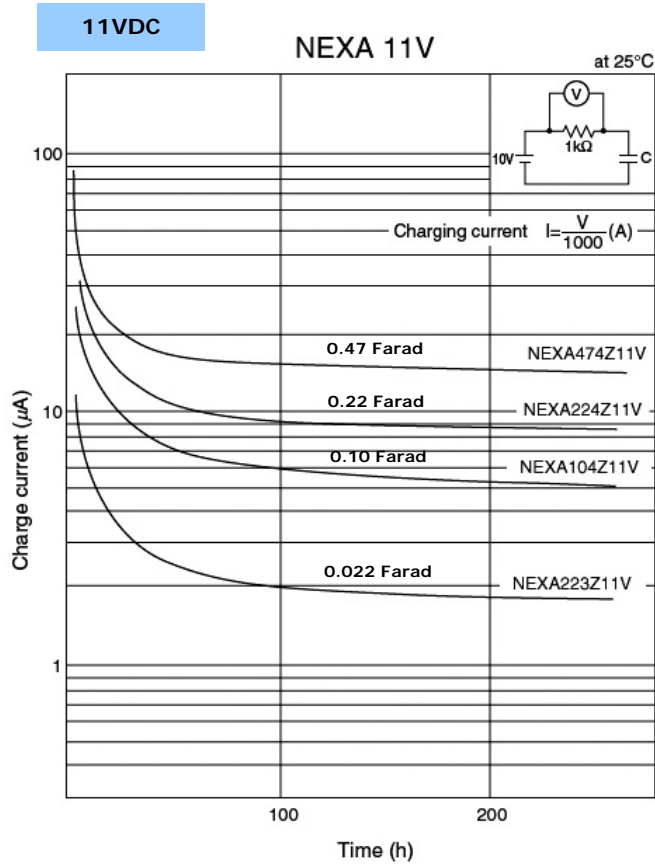

↑  
Higher capacitance value (Farad)  
Results in higher charge current ( $\mu\text{A}$ )

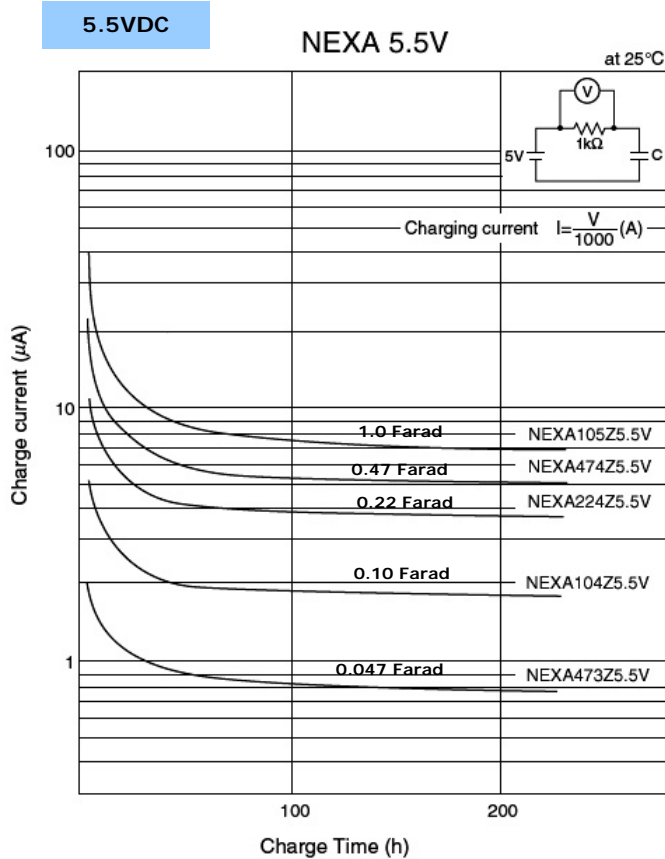

↑  
Higher capacitance value (Farad)  
Results in higher charge current ( $\mu\text{A}$ )



RE: Double Layer Capacitors

PN: NEX\_ series & NED\_ series

## 2.0 Discharge Rate (via connecting circuitry)

The rate of discharge of double layer capacitors will be determined by the resistance of connecting circuitry ( **GRAPH 2** ).

Discharge Tips:

- Increasing circuit resistance extends discharge rate
- Longer charging time will extend discharge rate

**GRAPH 2**

### DISCHARGE CHARACTERISTICS

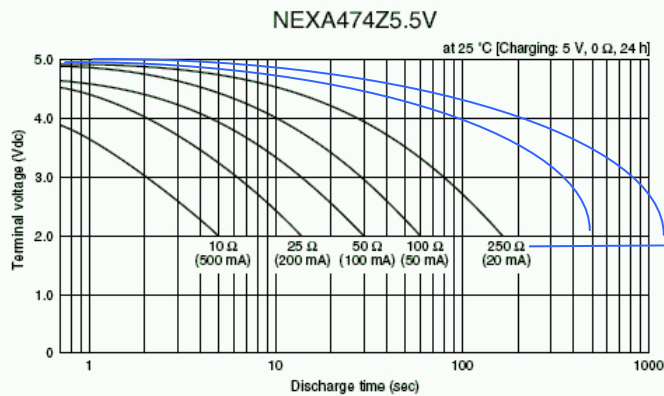

See discharge characteristics in **Appendix "A"**

Increasing circuit resistance extends discharge rate

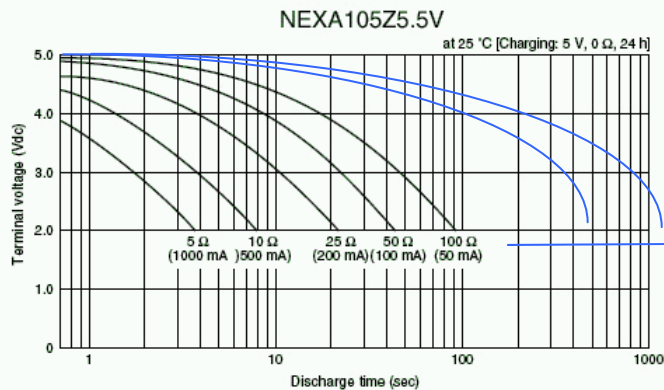

## 3.0 Voltage Holding Characteristic (self-discharge)

Self-discharge of double layer capacitors is characterized via the "**Voltage Holding Characteristic**" as shown on specification sheets, and specifies the minimum voltage after 24 hours at room temperature after the part has been charged for 24 hours at the rated voltage.

Example: **NEXG** and **NEXC** series for power back-up applications:

**Holding Voltage = 4.2VDC** (for 5.5VDC rated components) is the minimum voltage on the capacitor after 24 hours charge at 5.5VDC, followed by 24 hour period (+25°C) with no circuitry load resistance applied.

RE: Double Layer Capacitors

PN: NEX\_ series & NED\_ series

#### 4.0 Capacitance Value

Due to the very large capacitance and relatively high ESR of double layer capacitors the capacitance value cannot be measured using standard capacitance meters. Two methods are used to determine the capacitance value of double layer capacitors:

##### Charging Method:

1. **Constant resistance charge method** - Capacitance value test
  - o Prep component by shorting terminals for 30 minutes prior to capacitance value test
  - o Capacitance (F) is calculated by measuring the time constant ( $t$ ) until capacitor voltage reaches 0.632 of applied VDC ( $E_0$ )
  - o  $R_c$  is fixed resistance value
  - o **Capacitance (Farads) =  $t/R_c$**

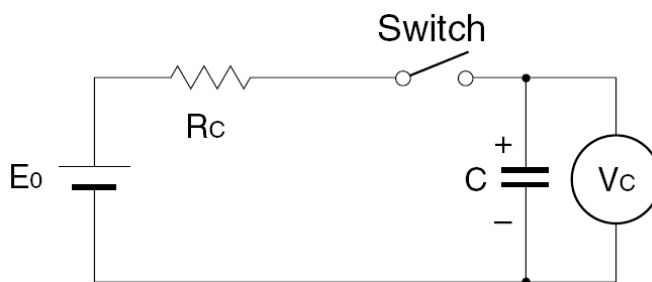

2. **Constant current charge – discharge method** - Capacitance value test
  - o Test method similar to common circuit application
  - o As discharge current increases the capacitance value will decrease as shown in example below
  - o Note: At low discharge currents the capacitance value may be 130 ~ 150% of nominal value, as shown in below graph (GRAPH 3)

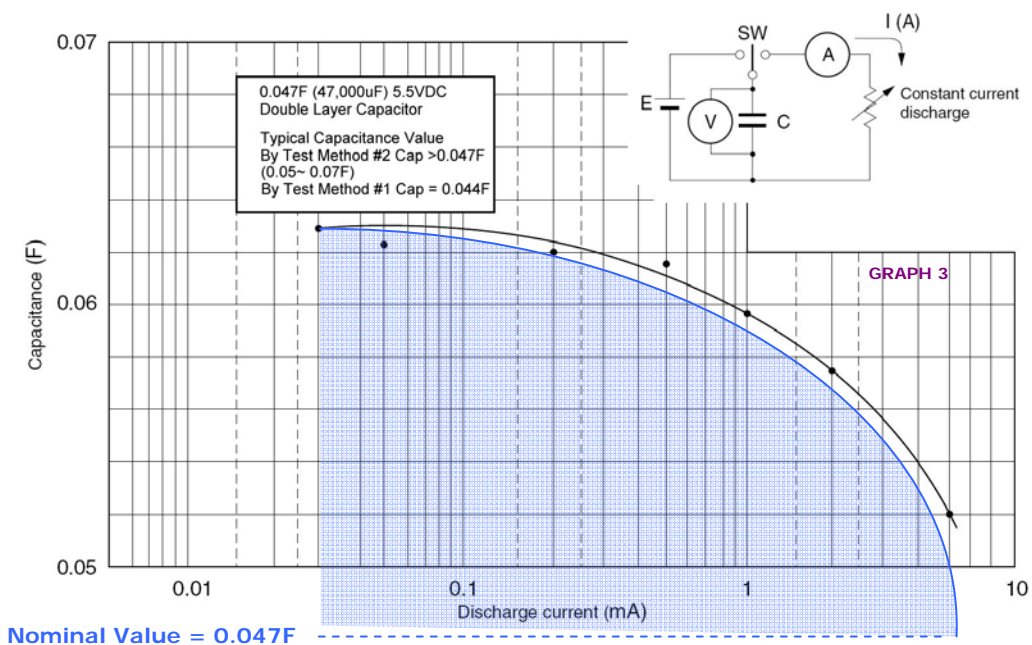

**5.0 Life Time**

Double layer capacitors, much like aluminum electrolytic capacitors, have a limited service life, as electrolyte will dissipate over time (and operating temperature) from the component, resulting in component wear-out. Lifetime estimation will be chiefly governed by operating temperature and can be estimated from graph "Capacitor Temperature Acceleration" (GRAPH 4). Lifetime is defined as point at which capacitance value is reduced by 70% of the initial capacitance value.

⚠ Failure mode of double layer capacitors is "open" mode under normal conditions, but short-circuit may result if extreme voltage, exceeding the maximum operating voltage is applied to the component. Water vapor, generated from water within the electrolyte (dilute sulfuric acid), gradually dissipates from the component in form of gas and is not dangerous. However, if unusual voltage such as greater than the maximum operating voltage is applied suddenly, leakage of liquid electrolyte or rupturing of component may result. When used for long periods at high operating temperature, the moisture of the electrolyte evaporates and the equivalent series resistance (ESR) increases. The fundamental failure mode is the open mode with ESR increase.

⚠ When using these capacitors, incorporate appropriate safety measures in your design, such as redundancy and protection measures.

Failure Rate- FIT: FIT rate for double layers capacitors is estimated to be 0.06 FIT

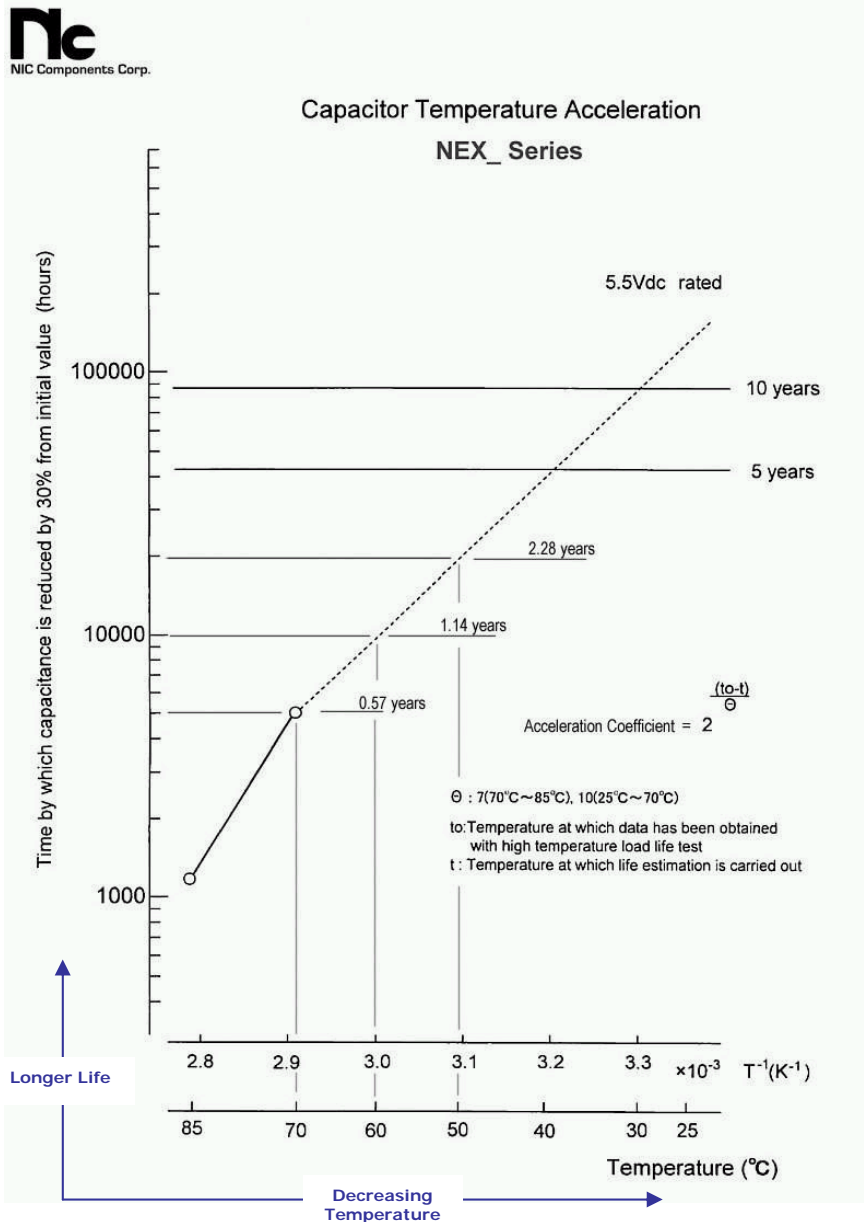

GRAPH 4

**6.0 Temperature Characteristics:**

**Typical Capacitance Change over Temperature (-25°C ~ +70°C)**

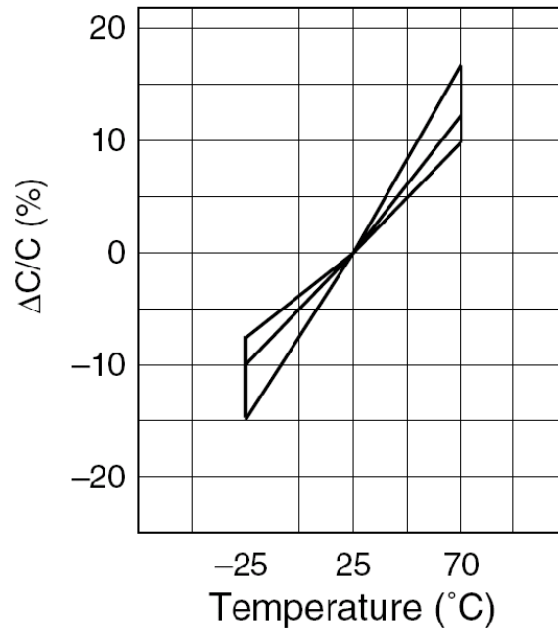

(Condition: -25°C → +25°C → +70°C, n = 10)

**SUMMARY: Increased capacitance as temperature increases**

**Typical 1KHz ESR Change over Temperature (-25°C ~ +70°C)**

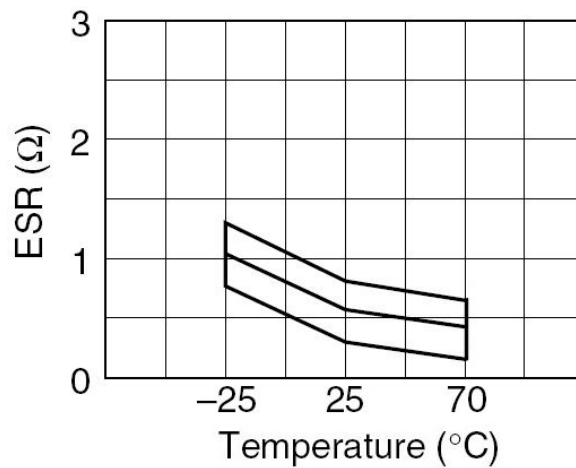

(Condition: -25°C

+70°C, n = 10)



Equivalent Series Resistance; sum of resistive losses within the capacitor

→ +25°C →

**SUMMARY: Decreasing ESR as temperature increases**

RE: Double Layer Capacitors

**Typical Discharge Characteristics over Temperature (+25°C, +50°C, +60°C & +70°C)**

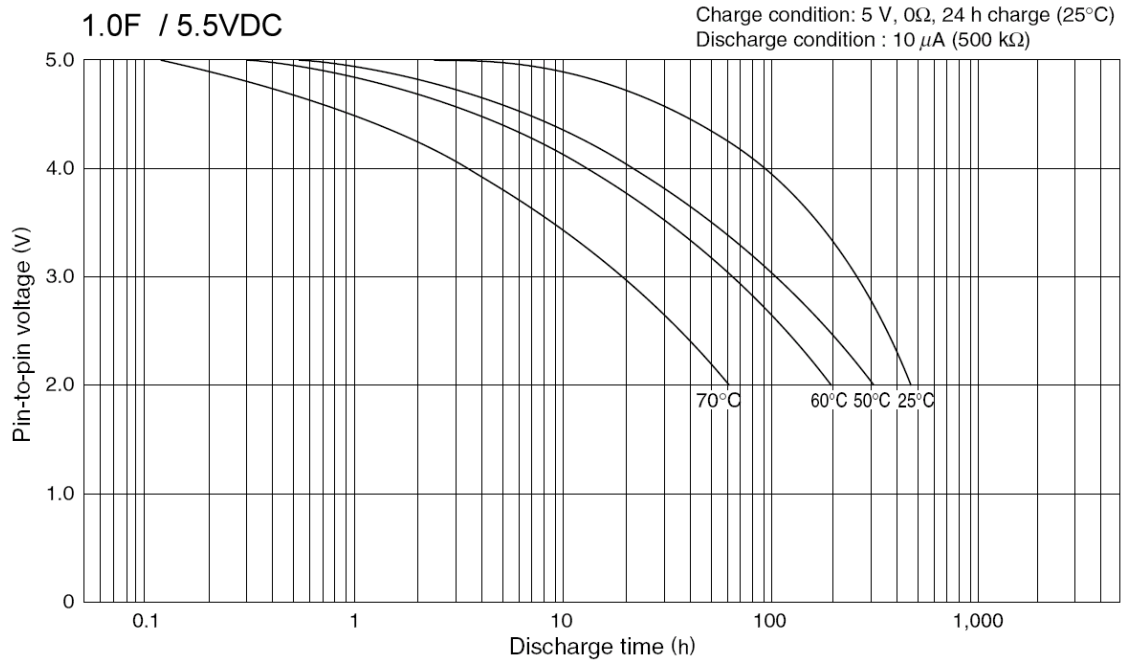

**SUMMARY: Decreasing charge as temperature increases**

**Circuit Applications:**

**Primary Use:**

Backup power source circuits for electric circuit operations and data preservation of microcomputers and memory devices during the power source interruption.

- Power failure, unplugging, operation error interruption
- Shock or unstable connection to primary power source (line or battery)
- Lack of sunlight on solar battery
- Anticipated power down - reboot - restart
- Changing of battery interruption

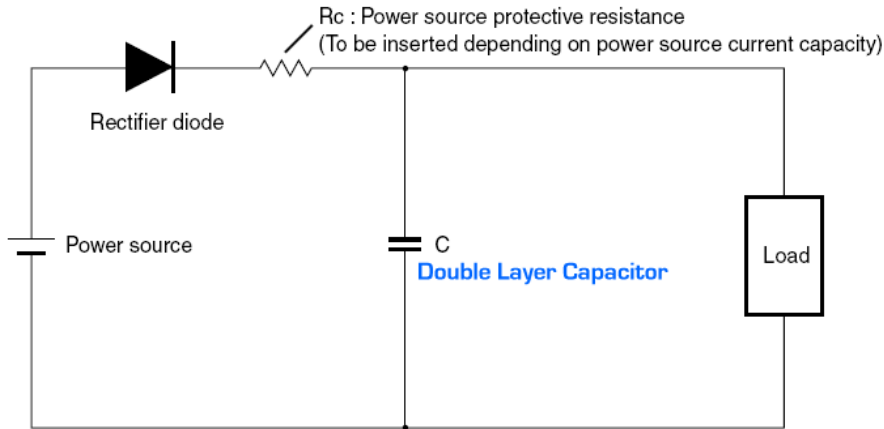

Power source of the memory component is backed up for period of time so that data preserved in memory is not lost.

**Examples of products employing backup circuits:**

- Measurement & Control systems
- Telephone equipment
- Audio - Video equipment
- Communication equipment
- Transportation
- Office automation equipment
- Smart metering – monitoring equipment

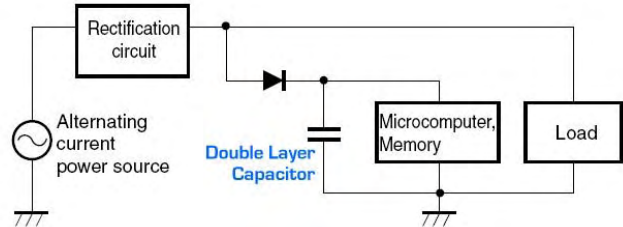
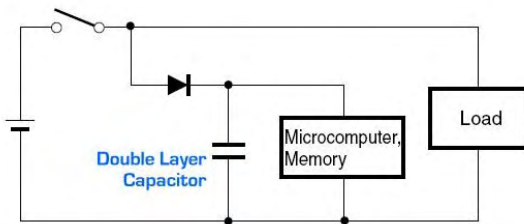

RE: Double Layer Capacitors

**Circuit Applications:**

---

**Power Failure Display Lighting**

Lighting of lamp or LED during power failure or when power source is off, gradually darkening after a certain time.

---

**Motor Drive**

Heavy load, stepped load or boost discharge applications:  
Double layer capacitor provides instantaneously power to memory and electronic circuits, for low power source capacity and initiating initial torque.

- HDD
- Motors
- Printers
- Relays

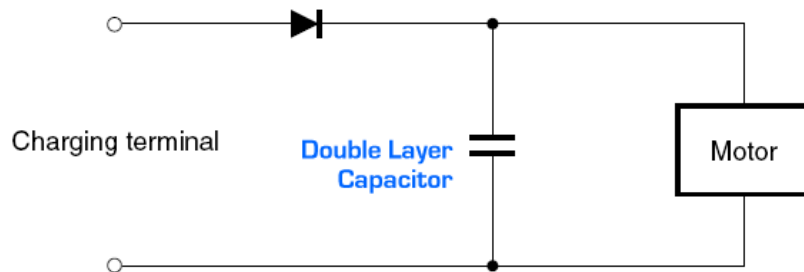

**Solar Battery Back-up**

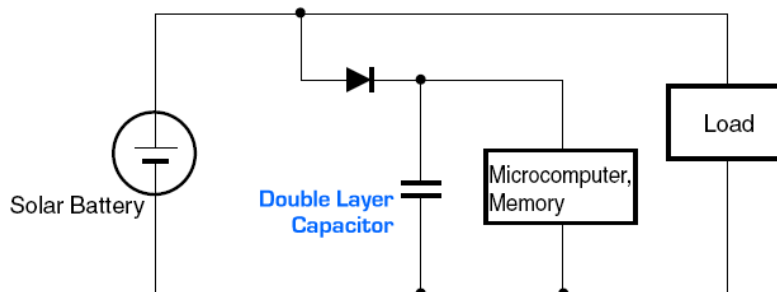

APPENDIX "A"

RE: Double Layer Capacitors

Constant Resistance Discharge Characteristics

100 Farad / 2.7VDC

**NEDR107N2.7V**

After 24 hour charge at 2.7V (0Ω +25°C)

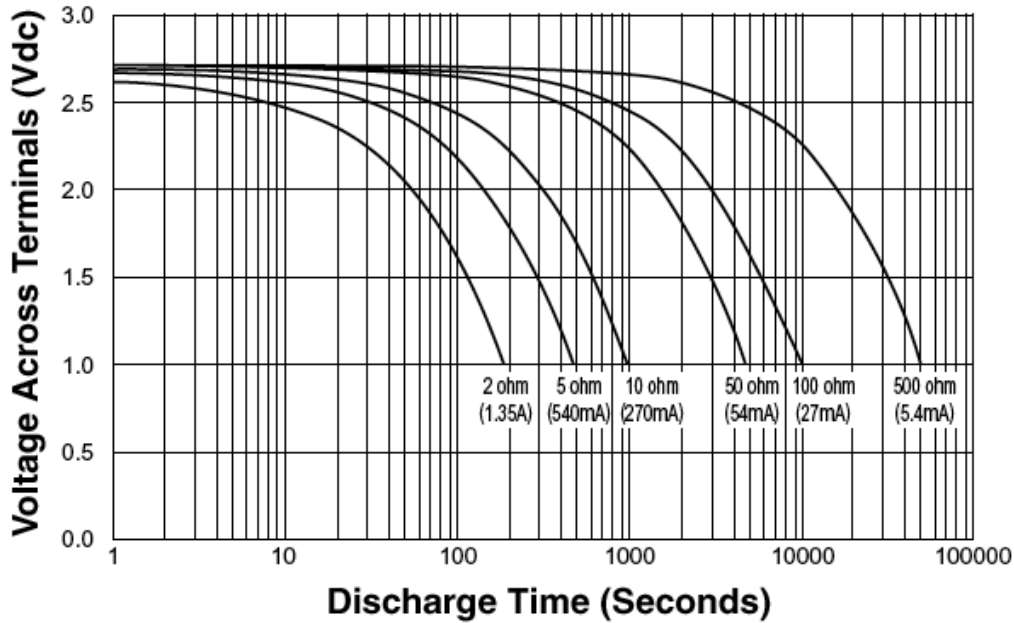

NEDL  
NEDR

**NEDR506N2.7V**

50 Farad / 2.7VDC

After 24 hour charge at 2.7V (0Ω +25°C)

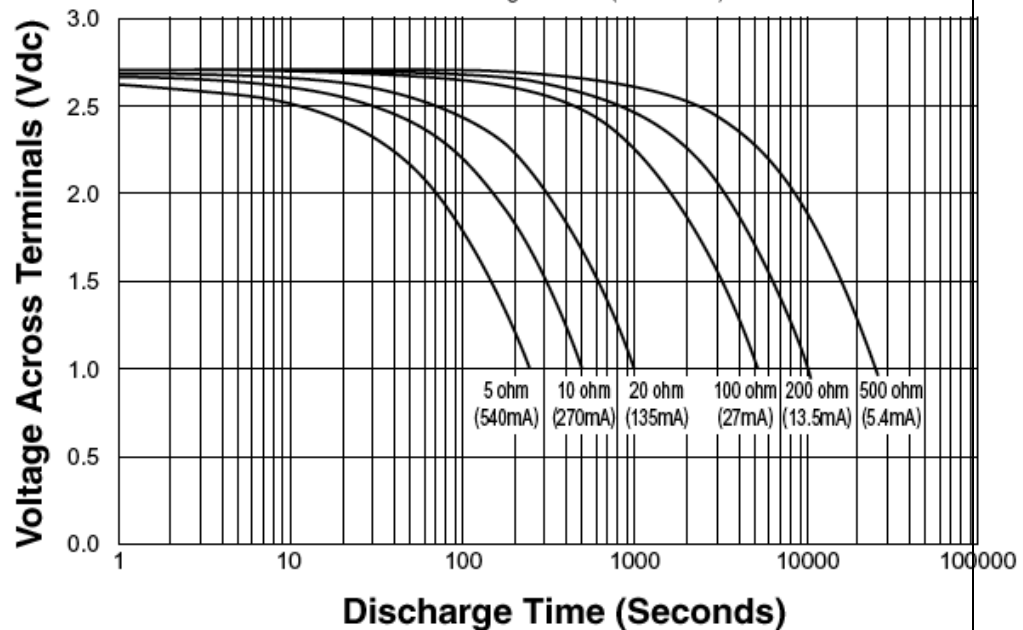



RE: Double Layer Capacitors

Constant Resistance Discharge Characteristics

22 Farad / 2.7VDC

**NEDR226N2.7V**

After 24 hour charge at 2.7V (0Ω +25°C)

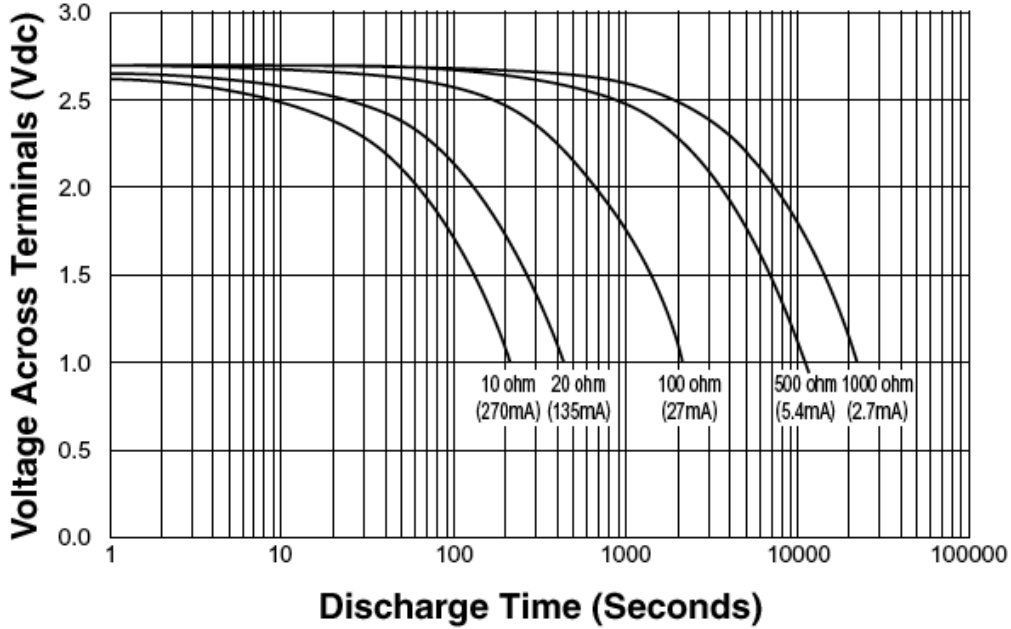

10 Farad / 2.7VDC

**NEDR106N2.7V**

After 24 hour charge at 2.7V (0Ω +25°C)

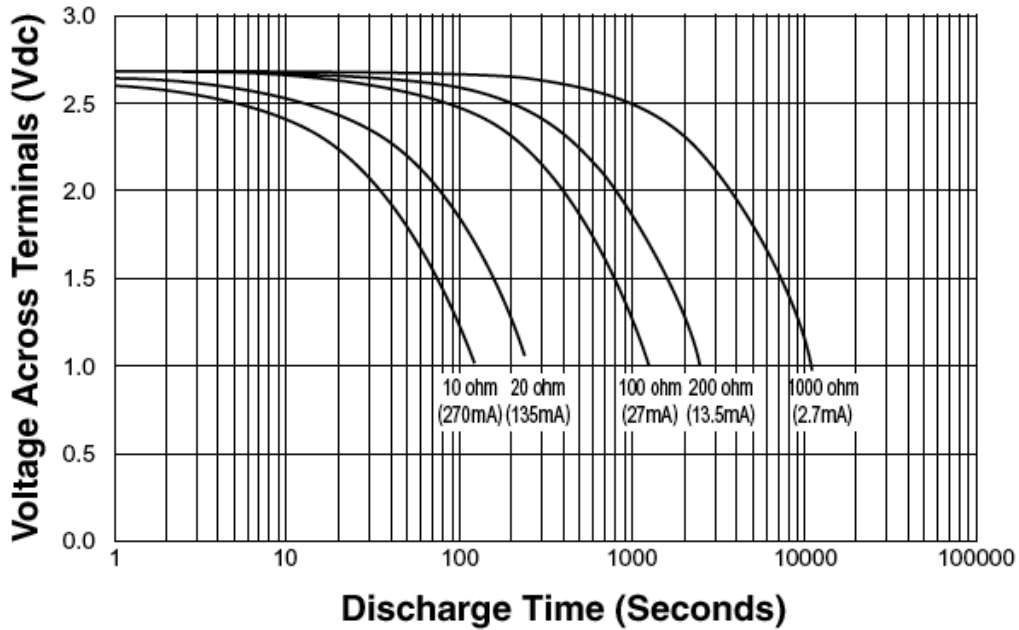

RE: Double Layer Capacitors

Constant Resistance Discharge Characteristics

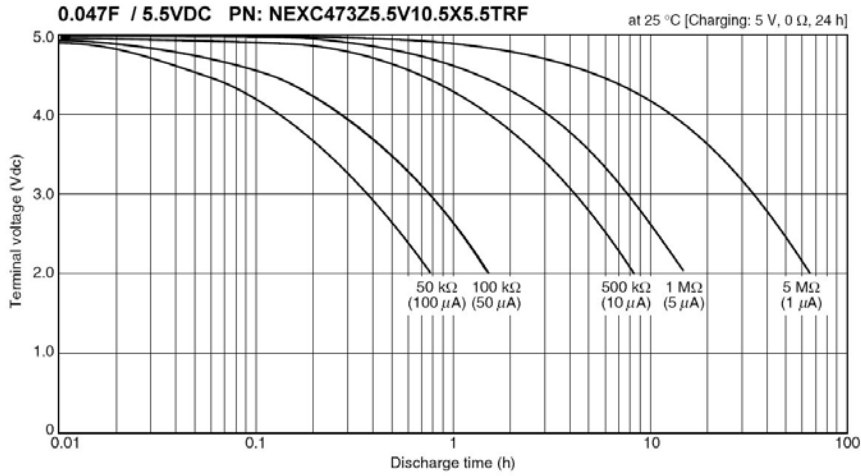

NEXC

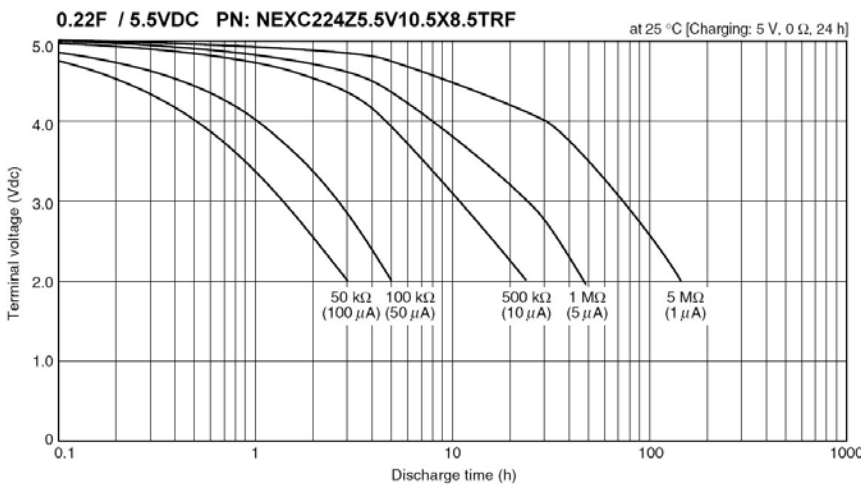
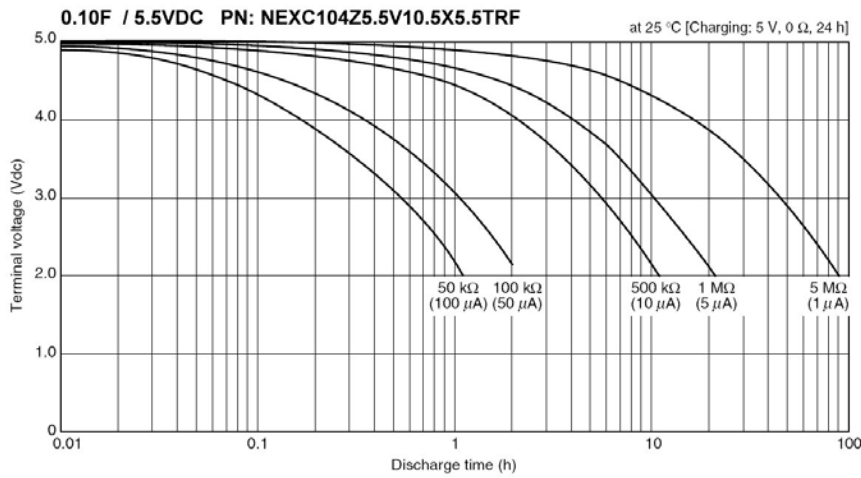

RE: Double Layer Capacitors

Constant Resistance Discharge Characteristics



NEXC

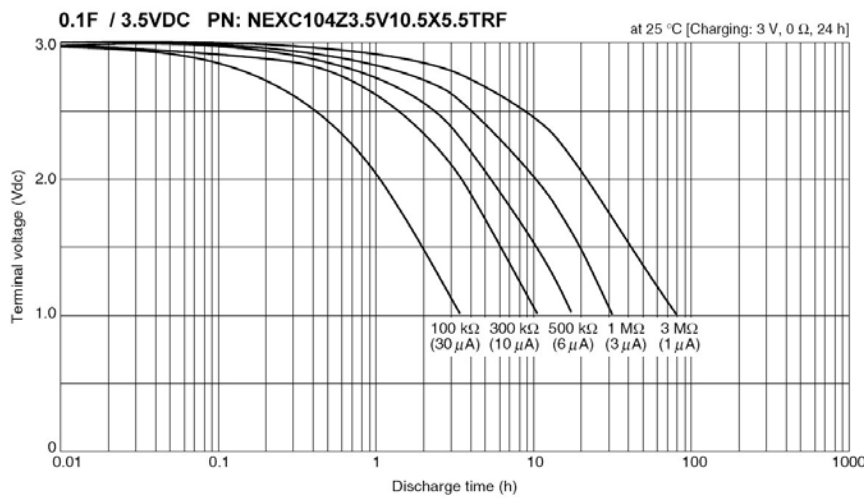
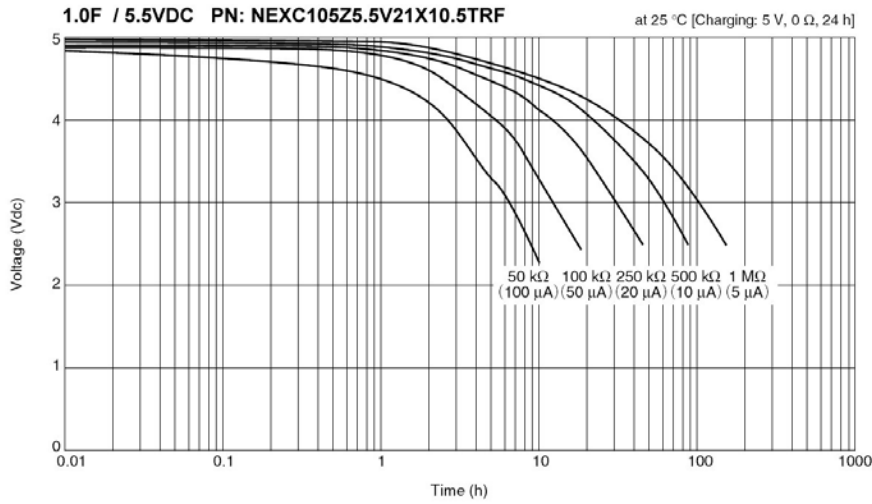
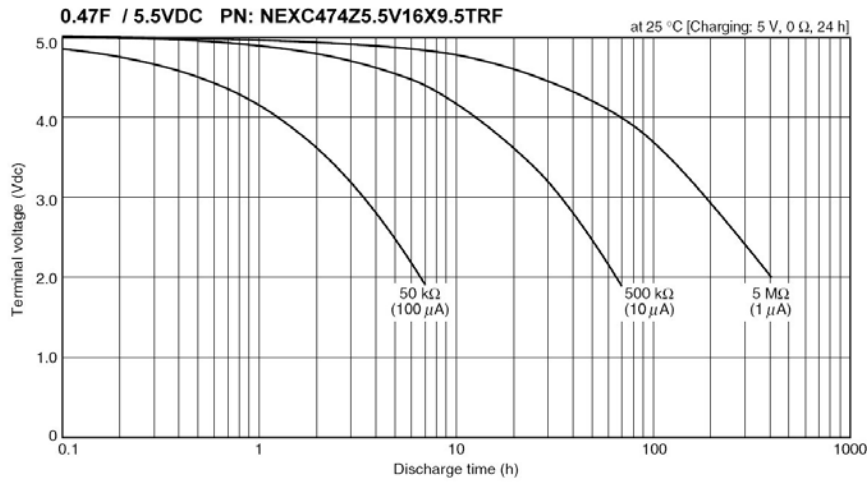

RE: Double Layer Capacitors

Constant Resistance Discharge Characteristics



NEXC

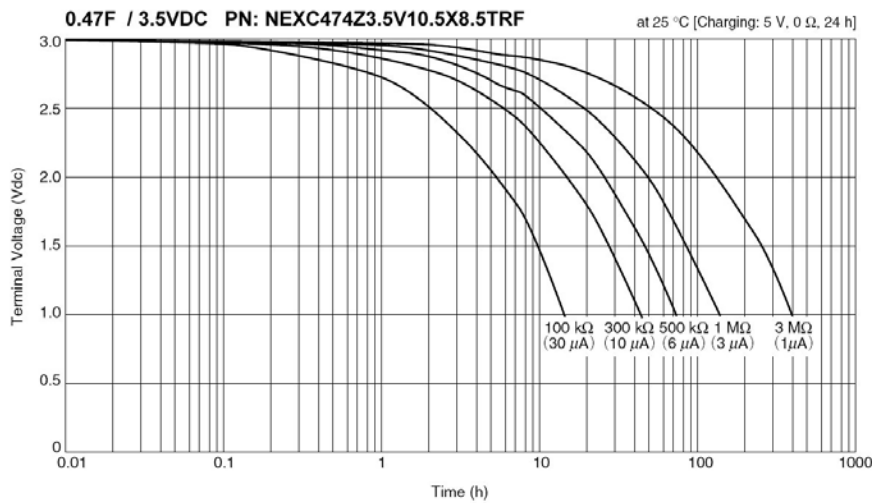
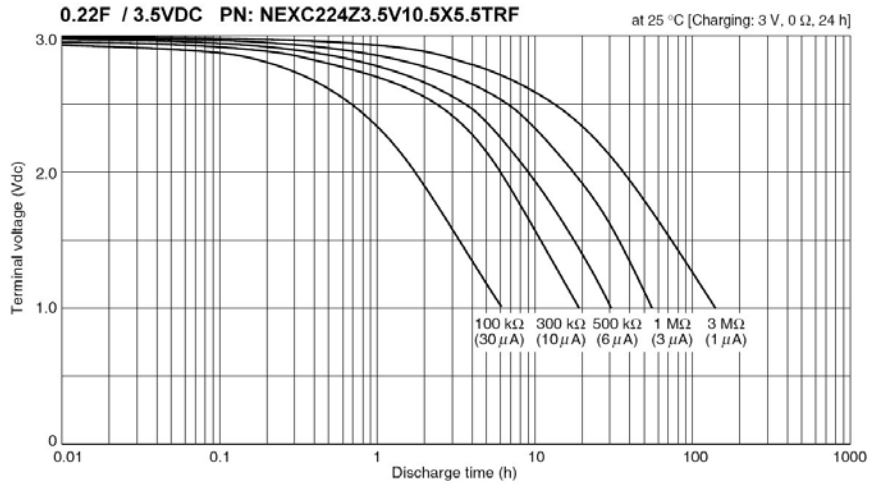

RE: Double Layer Capacitors

Constant Resistance Discharge Characteristics



DISCHARGE CHARACTERISTICS

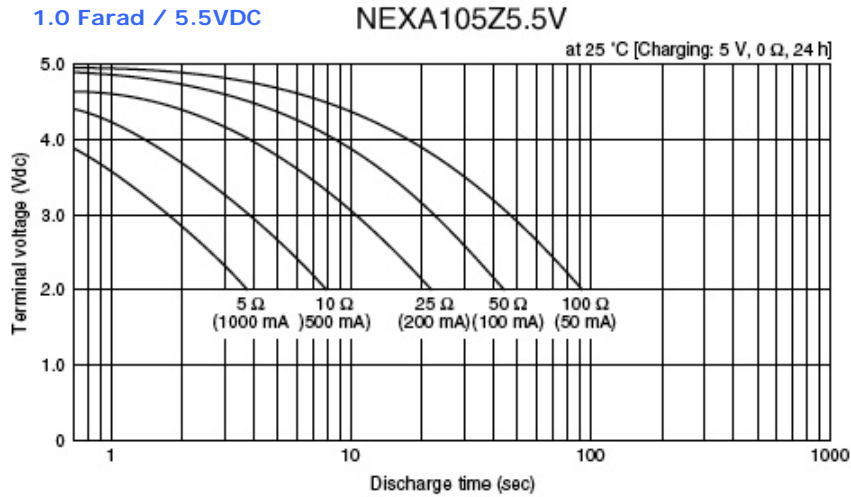
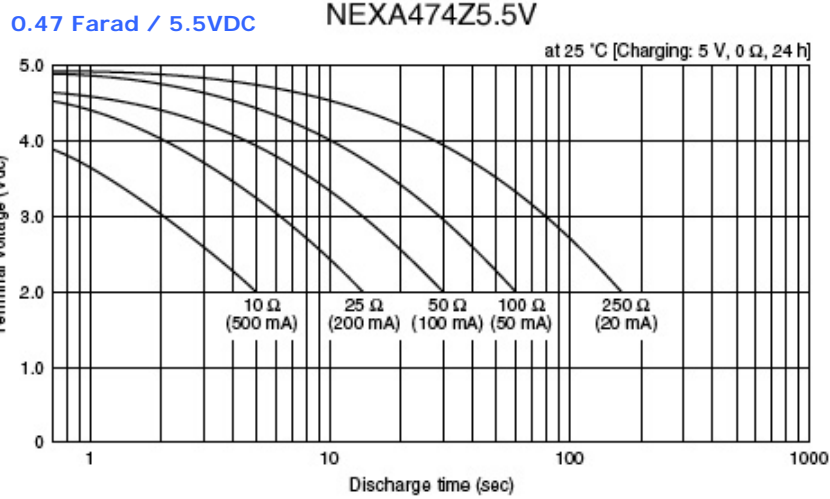

RE: Double Layer Capacitors

Constant Resistance Discharge Characteristics



**1.0 Farad / 5.5VDC PN: NEXS105Z5.5V28.5X14F**

at 25 °C [Charging: 5 V, 0 Ω, 24 h]

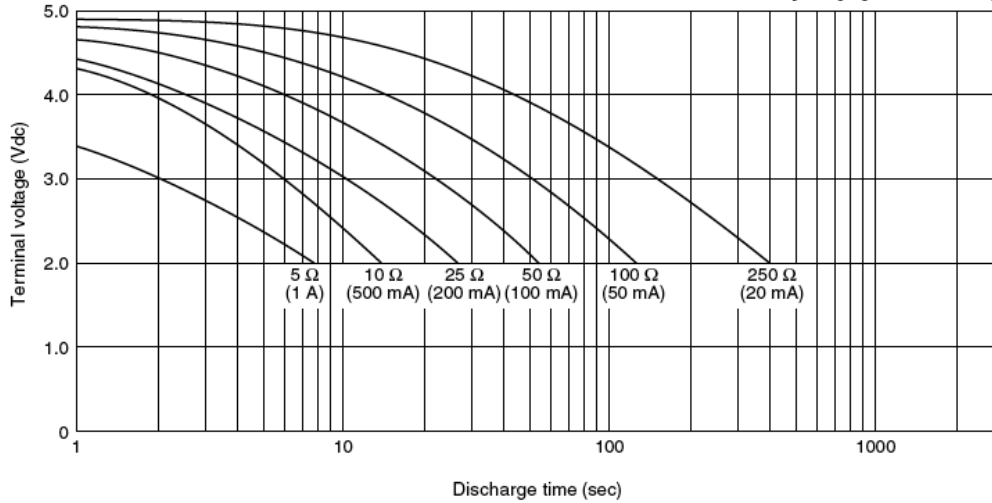

**3.3 Farad / 5.5VDC PN: NEXT335Z5.5V36.5X15F**

at 25 °C [Charging: 5 V, 0 Ω, 24 h]

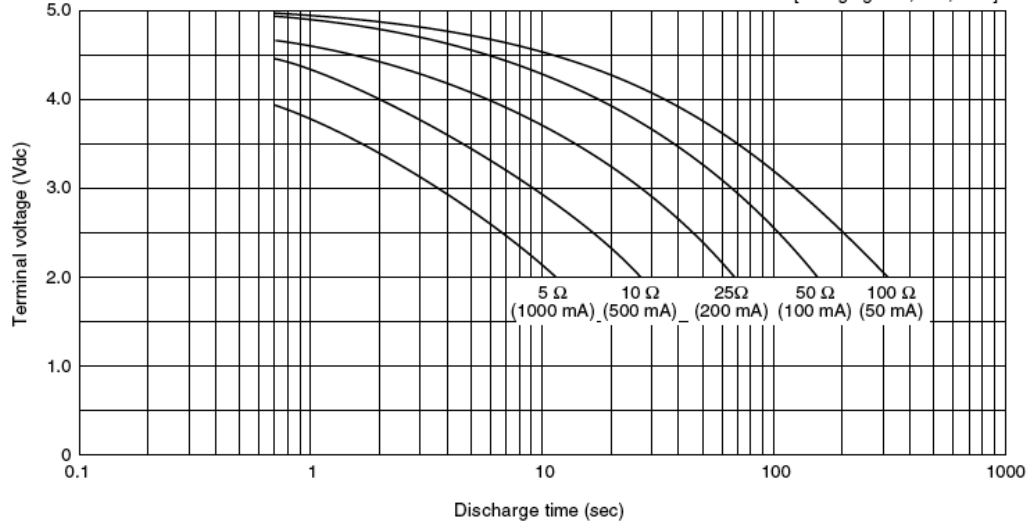

## Appendix B

### Double Layer Capacitor DC Resistance Values

Part Number	DC Resistance (ohms)	Cap. (Farad)	Voltage (VDC)
NEXA473Z5.5V	17	0.047	5.5
NEXA104Z5.5V	8	0.1	5.5
NEXA224Z5.5V	4.5	0.22	5.5
NEXA474Z5.5V	2.2	0.47	5.5
NEXA105Z5.5V	1.1	1.0	5.5
NEXA223Z11V	33	0.022	11
NEXA104Z11V	6.4	0.1	11
NEXA224Z11V	3.1	0.22	11
NEXA474Z11V	2.1	0.47	11
NEXC104Z3.5V	21	0.1	3.5
NEXC224Z3.5V	12	0.22	3.5
NEXC474Z3.5V	15	0.47	3.5
NEXC473Z5.5V	22	0.047	5.5
NEXC104Z5.5V	17	0.1	5.5
NEXC224Z5.5V	14	0.22	5.5
NEXC474Z5.5V	8.2	0.47	5.5
NEXC105Z5.5V	6	1.0	5.5
NEXCW104Z3.5V	25	0.1	3.5
NEXCW224Z3.5V	17	0.22	3.5
NEXCW474Z3.5V	17	0.47	3.5
NEXCW473Z5.5V	25	0.047	5.5
NEXCW104Z5.5V	17	0.1	5.5
NEXCW224Z5.5V	17	0.22	5.5
NEXG103Z5.5V	94	0.01	5.5
NEXG223Z5.5V	31	0.022	5.5
NEXG473Z5.5V	29	0.047	5.5
NEXG104Z5.5V	16	0.1	5.5
NEXG224Z5.5V	15	0.22	5.5
NEXG474Z5.5V	26	0.47	5.5
NEXG105Z5.5V	14	1.0	5.5
NEXG225Z5.5V	7	2.2	5.5
NEXG475Z5.5V	3.2	4.7	5.5
NEXGW104Z5.5V	12	0.1	5.5
NEXGW224Z5.5V	18	0.22	5.5

Part Number	DC Resistance (ohms)	Cap. (Farad)	Voltage (VDC)
NEXGW474Z5.5V	7	0.47	5.5
NEXGW105Z5.5V	3	1.0	5.5
NEXM103Z5.5V	65	0.01	5.5
NEXM223Z5.5V	33	0.022	5.5
NEXM473Z5.5V	26	0.047	5.5
NEXM104Z5.5V	32	0.1	5.5
NEXM224Z5.5V	12	0.22	5.5
NEXR223Z5.5V	72	0.022	5.5
NEXR473Z5.5V	50	0.047	5.5
NEXR104Z5.5V	38	0.1	5.5
NEXR224Z5.5V	55	0.22	5.5
NEXR474Z5.5V	38	0.47	5.5
NEXR105Z5.5V	18	1.0	5.5
NEXS223Z5.5V	51	0.022	5.5
NEXS473Z5.5V	18	0.047	5.5
NEXS104Z5.5V	11	0.1	5.5
NEXS224Z5.5V	9	0.22	5.5
NEXS474Z5.5V	4.2	0.47	5.5
NEXS105Z5.5V	2.9	1.0	5.5
NEXS474Z11V	3.4	0.47	11
NEXS105Z11V	5	1.0	11
NEXS105Z12V	5	1.0	12
NEXS505Z12V	2	5.0	12
NEXT104Z5.5V	23	0.1	5.5
NEXT224Z5.5V	16	0.22	5.5
NEXT474Z5.5V	5.4	0.47	5.5
NEXT105Z5.5V	2.9	1.0	5.5
NEXT225Z5.5V	2.1	2.2	5.5
NEXT335Z5.5V	1.3	3.3	5.5
NEXT565Z5.5V	0.8	5.6	5.5